

LED



Spotlight



Floodlight

Ex Code: Ex d IIC T6

Standard: GB3836.1, GB3836.2

IEC60079-1:2007,MOD



Drawing of dimension (Dimensions in mm)

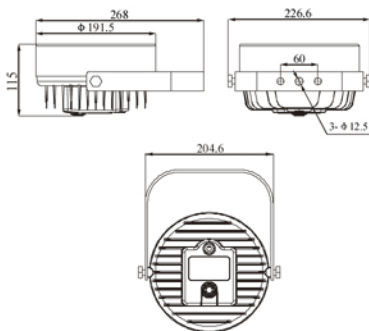

Application

This products is designed for use on the well serving unit, tractor hoist, oil derrick and other vehicles in the explosive area.

Characteristics

- The lighting system consists of increased safety control box., lamp and cable.
- The generator on the tractor hoist will power the units when the vehicle is working, and it is also recharging the units at the same time.
- Good illuminate effect: The four lamps are mounting on the oil derrick. The floodlight can provide large area illuminating. The spotlight can mount on the wellhead. We can provide more lamps according to customers' requirements.
- When the vehicle starts, it will charge the units automatically. The extra energy will be saved to the control box.
- Two discharge switches. When the tractor hoist starts, operator should use the regular discharge switch. Or the battery switch should be turn on.
- When blowout happens, the battery in the control box can power the units for 10 hours. Meeting the emergency lighting requirement.

Components

- Increased safety control box: battery, explosion proof switch, explosion junction box, control circuit.
- Lamp: 2-spotlight; 2-floodlight.
- The lamps are mounting on the derrick, the illuminating direction is adjustable. The lamps are connected to the control box by cables (15meters length)

Main specification

Specification	BW3210A-4	
Rated voltage	24VDC	
Rated power	4,30W	
Continuous Working Time	> 10h	
Dimension	Lamp	φ 191.5,115cm
	Control box	396,332,344cm
Weight	83Kg	